

Full Bore, 2-Piece Body, Blowout-proof Stem, Screwed Ends.

MSS Specification Valve

FEATURE

1. Suitable Medium : Water, Sea Water, Non-causticity
: liquid, Saturated Steam
2. Max.Working Pressure : 600 PSI
3. Max.Temperature : -10° to 100° C
4. Thread : BS 21

BALL VALVE Fig. BV-600L

600 W.O.G



WORK PRESSURE		TEST	
Saturated Steam	Cold Water, Oil, Gas	Shell (Water)	Seat (Air)
Psi 150	600	900	80
Bar 10.3	41.4	62.1	5.5

SIZE 1/4" - 3" : Working Pressures 600 PSI.

MATERIALS

NO.	NAME OF PARTS	MATERIAL	ASTM SPECIFICATIONS
1	Body	Forged Brass	
2	Seat	PTFE	
3	Stem	Forged Brass	B124-C37700
4	Handle	Steel Zinc plated	A307 Gr.A
5	Handle Nut*	Stainless Steel	A167-304
6	Gland	Forged Brass	B124-C37700
7	Packing	PTFE	
8	Ball	Forged Brass (Hand Chromuim plated)	B283-C37700
9	Cap	Forged Brass	B283-C37700

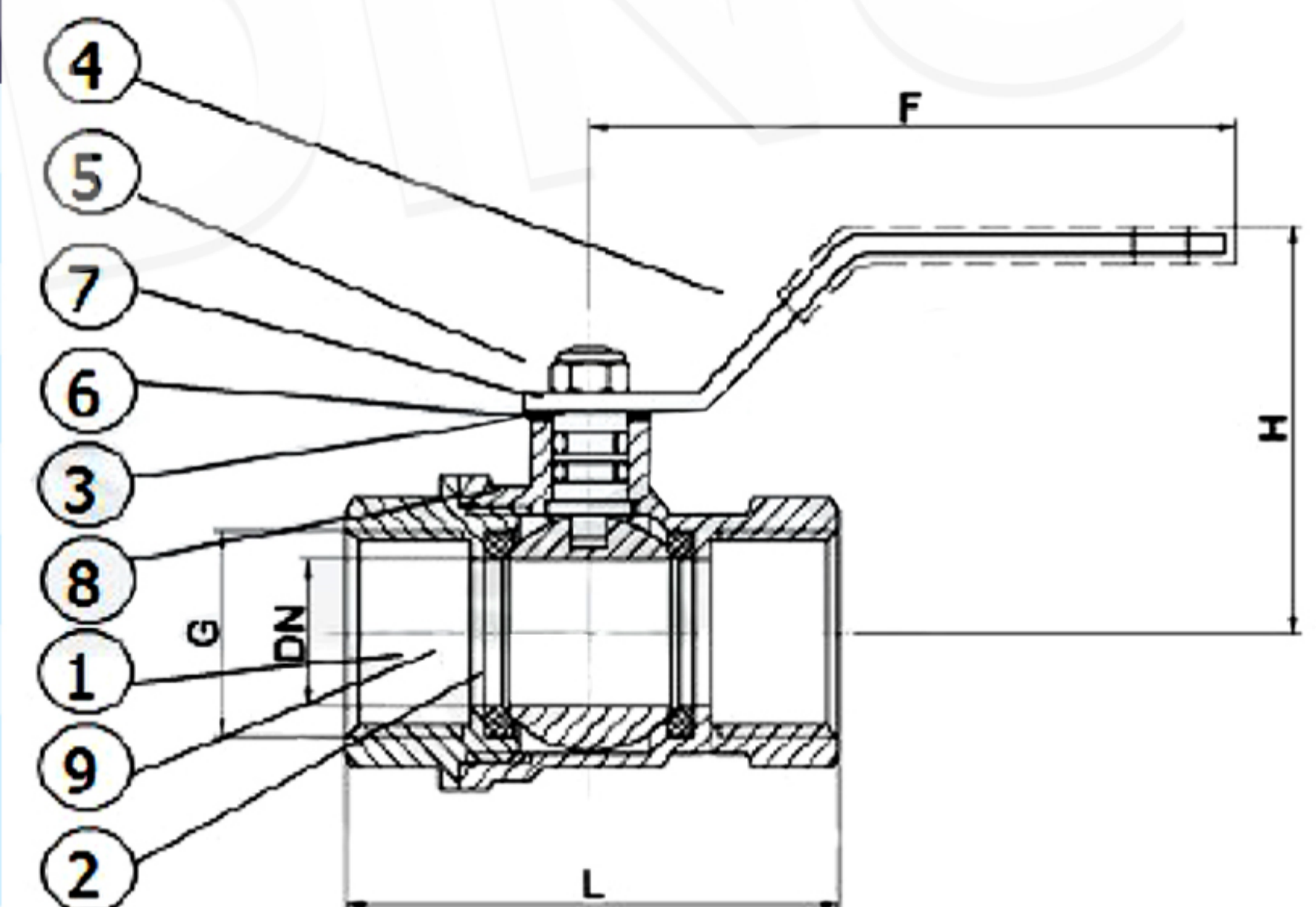

* Handle Nut : Size : 1/4" - 2" Stainless Steel. 2.1/2" - 3" Forged Brass

Note :

1. End threads conform to the British standard taper pipe threads.
2. Each valve is individually tested for seat and shell tightness.
3. Minimum and maximum working temperature - 10° to 100°C
4. The following accessories are available upon request.
- Momory stop , - Extension stem , - Special handle
5. These valve conform to the requirements of MSS SP-110

Application :

Suitable for water services, heating and air-conditioning plants, compressed air systems.

DIMENSIONS

Unit : mm.

SIZE	DN	L	H	H	Weight / kgs
1/4"	8	41	38	82	0.11
3/8"	10	45	43	82	0.12
1/2"	15	51	50	88	0.19
3/4"	20	57	57	99	0.25
1"	25	68	62	109	0.42
1.1/4"	32	80	78	116	0.69
1.1/2"	40	89	100	160	0.90
2"	50	100	103	160	1.35
2.1/2"	65	124	130	245	2.6
3"	80	141	141	245	3.6